

**BeiDou Navigation Satellite System**  
**Signal In Space**  
**Interface Control Document**  
**Satellite Based Augmentation System**  
**Service Signal BDSBAS-B1C**  
**(Version 1.0)**



**China Satellite Navigation Office**

**July, 2020**



## TABLE OF CONTENTS

1	Statement .....	1
2	Scope .....	2
3	BDSBAS SF Service Overview .....	3
3.1	Space Constellation .....	3
3.2	Coordinate System .....	3
3.3	Time System .....	3
4	Signal Characteristics .....	4
4.1	Carrier Frequency .....	4
4.2	Spurious Transmissions .....	4
4.3	Modulation .....	4
4.4	Carrier Phase Noise .....	4
4.5	Signal Spectrum .....	4
4.6	Doppler Shift .....	4
4.7	Carrier Frequency Stability .....	4
4.8	Polarization .....	5
4.9	Code/Carrier Frequency Coherence .....	5
4.10	User Received Signal Levels .....	5
4.11	Correlation Loss .....	5
4.12	Maximum Code Phase Deviation .....	5
4.13	Signal Codes .....	5
5	Message Structure .....	7
5.1	Data Code .....	7
5.2	Message Types .....	7
5.3	Message Format .....	8
5.3.1	Message Type 0 .....	8
5.3.2	Message Type 1 .....	8
5.3.3	Message Types 2-5 .....	9

5.3.4	Message Type 6	11
5.3.5	Message Type 7	12
5.3.6	Message Type 9	13
5.3.7	Message Type 10	15
5.3.8	Message Type 12	15
5.3.9	Message Type 17	17
5.3.10	Message Type 18	18
5.3.11	Message Type 24	20
5.3.12	Message Type 25	21
5.3.13	Message Type 26	23
5.3.14	Message Type 28	31
5.3.15	Message Type 62	33
5.3.16	Message Type 63	33
5.4	Degradation Parameters	33
5.4.1	Fast and Long-Term Correction Degradation	33
5.4.2	Degradation of Ionospheric Corrections	36
6	Abbreviations	38

## LIST OF FIGURES

Figure 5-1	Rate 1/2 Convolutional Encoding .....	7
Figure 5-2	BDSBAS-B1C Message Format .....	8
Figure 5-3	Message Type 1 .....	8
Figure 5-4	An example of the relationship among PRN mask, PRN code number and PRN mask number .....	9
Figure 5-5	Message Types 2-5 .....	10
Figure 5-6	Message Type 6 .....	12
Figure 5-7	Message Type 7 .....	12
Figure 5-8	Message Type 9 .....	14
Figure 5-9	Message Type 10 .....	15
Figure 5-10	Message Type 12 .....	16
Figure 5-11	Message Type 17 .....	17
Figure 5-12	Message Type 18 .....	19
Figure 5-13	Predefined Global IGP Grid .....	20
Figure 5-14	Message Type 24 .....	20
Figure 5-15	Message Type 25 with Velocity Code=0 .....	21
Figure 5-16	Message Type 25 with Velocity Code=1 .....	22
Figure 5-17	Message Type 26 .....	24
Figure 5-18	Ionospheric Correction Processing Flow .....	25
Figure 5-19	Ionospheric Pierce Point Geometry .....	26
Figure 5-20	IGP Interpolation .....	28
Figure 5-21	Four-Point Interpolation Definitions .....	29
Figure 5-22	Three-Point Interpolation Definitions .....	30
Figure 5-23	Message Type 28 .....	31
Figure 5-24	Processing Flow of Fast and Long-Term Correction Degradation .....	34

## LIST OF TABLES

Table 4-1	The signal codes of BDSBAS-B1C .....	6
Table 5-1	Message Types Broadcast by BDSBAS-B1C .....	7
Table 5-2	PRN Mask Assignments .....	9
Table 5-3	Evaluation of UDREI .....	10
Table 5-4	UDRE Degradation Factor and User Time-Out Interval Evaluation .....	13
Table 5-5	Message Type 9 Parameters .....	14
Table 5-6	Message Type 10 Degradation Parameters .....	15
Table 5-7	Message Type 12 Parameters .....	16
Table 5-8	UTC Standard Identifier .....	16
Table 5-9	Message Type 17 Parameters .....	17
Table 5-10	Definition of 8-bit Health and Status .....	18
Table 5-11	Definition of Service Provider ID .....	18
Table 5-12	IGP Bands 0-8 .....	19
Table 5-13	IGP Bands 9-10 .....	19
Table 5-14	Definition of 106-bit with Velocity Code=0 .....	22
Table 5-15	Definition of 106-bit with Velocity Code=1 .....	23
Table 5-16	Message Type 26 Parameters .....	24
Table 5-17	Evaluation of GIVEI .....	24
Table 5-18	Message Type 28 Parameters .....	31

## **1 Statement**

China Satellite Navigation Office is responsible for the preparation, revision, distribution, and retention of the BeiDou Navigation Satellite System (BDS) Signal In Space Interface Control Documents (hereinafter referred to as SIS ICD), and reserves the rights for final interpretation of this document.

## 2 Scope

The construction and development of the BeiDou Navigation Satellite System is divided into three phases: BDS-1, BDS-2, and BDS-3 in sequence.

The BeiDou Satellite Based Augmentation System (“BDSBAS”) is an important part of BDS, and will provide the Single Frequency (SF) service through BDSBAS-B1C signal and the Dual-Frequency Multi-Constellation (DFMC) service through BDSBAS-B2a signal for users in China and surrounding areas, in accordance with the International Civil Aviation Organization (ICAO) standards.

Based on the Satellite Based Augmentation System (SBAS) Standards And Recommended Practices (SARPs) of ICAO “Convention on International Civil Aviation” Annex 10 Aeronautical Telecommunications Volume I Radio Navigation Aids, this document defines the characteristics of the BDSBAS SF service signal BDSBAS-B1C transmitted by the BDS Geostationary Earth Orbit (GEO) satellites.



### **3 BDSBAS SF Service Overview**

#### **3.1 Space Constellation**

The space constellation of BDSBAS includes 3 BDS GEO satellites. The 3 GEO satellites operate in orbit at an altitude of 35,786 kilometers and are located at 80°E, 110.5°E, and 140°E, which are using Pseudo Random Noise (PRN) code 144, 143 and 130, respectively.

#### **3.2 Coordinate System**

The coordinate system of BDSBAS is WGS-84.

#### **3.3 Time System**

The BeiDou Navigation Satellite System Time (BDT) is adopted by the BDS as time reference. The deviation of BDSBAS SF service network time ( $SNT = BDT + 14s$ ) to GPS Time (GPST) is within 50 nanoseconds ( $|SNT - GPST| \leq 50ns$ ).

## **4 Signal Characteristics**

### **4.1 Carrier Frequency**

The carrier frequency is 1575.42MHz.

### **4.2 Spurious Transmissions**

Spurious transmissions will be at least 40dB below the unmodulated carrier power.

### **4.3 Modulation**

Message symbols at a rate of 500 symbols per second (sps) will be added modulo-2 to a 1023-bit PRN code, which will then be Bi-Phase Shift-Keyed (BPSK) modulated onto the carrier at a rate of 1.023 M-chips per second.

### **4.4 Carrier Phase Noise**

The phase noise spectral density of the unmodulated carrier will be such that a phase-locked loop of 10Hz one-sided noise bandwidth will be able to track the carrier to an accuracy of 0.1 radians rms.

### **4.5 Signal Spectrum**

The broadcast signal will be at 1575.42MHz. At least 95% of the broadcast power will be contained within a  $\pm 12$ MHz band centered at the carrier frequency. The bandwidth of the signal transmitted by a BDS GEO satellite will be at least 2.2MHz.

### **4.6 Doppler Shift**

The Doppler shift on the signal broadcast by BDS GEO satellites will be less than 40 meters per second (about 210Hz at 1575.42MHz).

### **4.7 Carrier Frequency Stability**

The short-term stability of the carrier frequency (square root of the Allan Variance) at the input of the user's receiver antenna will be better than  $5 \times 10^{-11}$  over 1 to 10 seconds, excluding the effects of the ionosphere and Doppler.

## **4.8 Polarization**

The broadcast signal will be Right-Handed Circularly Polarized (RHCP). The ellipticity will be no worse than 2dB for the angular range of  $\pm 9.1^\circ$  from bore sight.

## **4.9 Code/Carrier Frequency Coherence**

The short-term (<10 seconds) fractional frequency difference between the code phase rate and the carrier frequency will be less than  $5 \times 10^{-11}$  (one sigma). Over the long term (<100 seconds), the difference between the change in the broadcast code phase, converted to carrier cycles by multiplying the number of code chips by 1540, and the change in the broadcast carrier phase, in cycles, will be within one carrier cycle, one sigma.

## **4.10 User Received Signal Levels**

At all unobstructed locations near the ground from which the BDS GEO satellite is observed at an elevation angle of 5 degrees or higher, the level of the received BDSBAS-B1C signal at the antenna port of a 3dBi linearly polarized antenna is within the range of -161dBW to -153dBW for all antenna orientations orthogonal to the direction of propagation.

## **4.11 Correlation Loss**

The correlation loss resulting from modulation imperfections and filtering inside the BDS GEO satellite payload will be less than 1dB.

## **4.12 Maximum Code Phase Deviation**

The maximum uncorrected code phase of the BDSBAS-B1C signal will not deviate from the equivalent SNT by more than  $2^{-20}$  seconds.

## **4.13 Signal Codes**

The signal codes of BDSBAS-B1C are defined by PRN code, G2 delay in chips and initial G2 state, which are listed in Table 4-1.

Table 4-1 The signal codes of BDSBAS-B1C

<b>PRN Code</b>	<b>G2 Delay (Chips)</b>	<b>Initial G2 state (Octal)</b>	<b>First 10 Chips (Octal)</b>
130	355	0341	1436
143	307	1312	0465
144	127	1060	0717

## 5 Message Structure

### 5.1 Data Code

The message data rate will be 250 bits per second (bps). The data will always be rate 1/2 convolutional encoded with a Forward Error Correction (FEC) code, as shown in Figure 5-1. Therefore, the symbol rate of output is 500 symbols per second (sps).

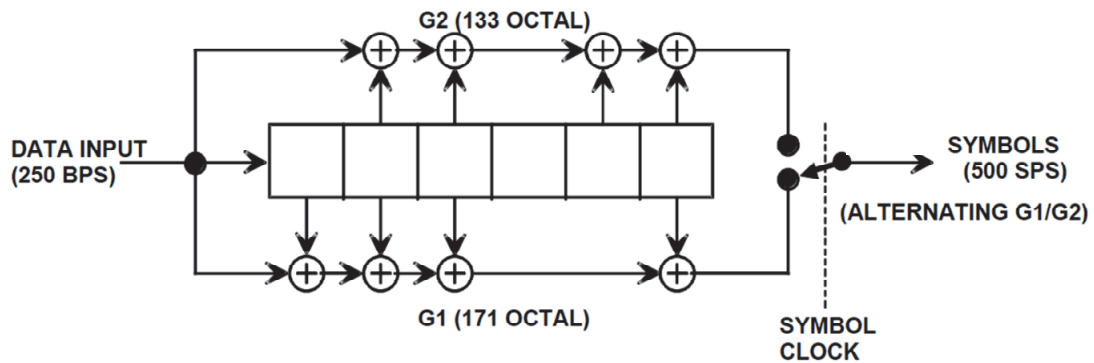

Figure 5-1 Rate 1/2 Convolutional Encoding

### 5.2 Message Types

Message types broadcast by BDSBAS-B1C signal are shown in Table 5-1.

Table 5-1 Message Types Broadcast by BDSBAS-B1C

Type	Contents
0	Don't use for safety application (BDSBAS testing)
1	PRN Mask Assignments
2-5	Fast Corrections
6	Integrity Information
7	Fast Correction Degradation Factor
9	GEO Satellite Ephemeris
10	Degradation Parameters
12	SNT/UTC Offset Parameters
17	GEO Satellite Almanacs
18	Ionospheric Grid Point Masks
24	Mixed Fast Corrections/Long Term Satellite Error Corrections
25	Long Term Satellite Error Corrections
26	Ionospheric Delay Corrections
28	Clock-Ephemeris Covariance Matrix Message
62	Internal Test Message
63	Null Message

### 5.3 Message Format

Each type of message broadcast by BDSBAS-B1C signal is 250 bits with a broadcasting time of 1 second. The 8-bit preamble starts at bit 0 of the 250-bit message followed by the 6-bit message type identifier at bit 8. The 212-bit data field then starts at bit 14, followed by 24-bit of Cyclic Redundancy Check (CRC) parity. The message format is shown in Figure 5-2.

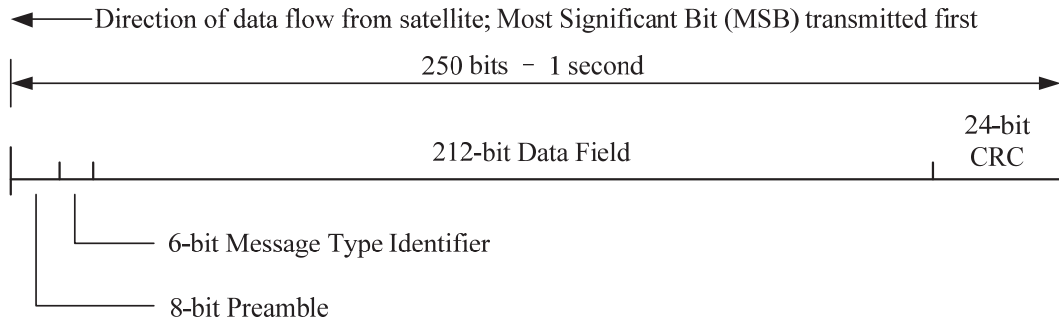

Figure 5-2 BDSBAS-B1C Message Format

#### 5.3.1 Message Type 0

Message Type 0 will be used primarily during system testing. The receipt of a Message Type 0 will result in the cessation of the use of BDSBAS-B1C signal for safety applications. In addition, that BDSBAS-B1C signal will be deselected for at least one minute.

#### 5.3.2 Message Type 1

The PRN Mask is given in Message Type 1, the message format is shown in Figure 5-3.

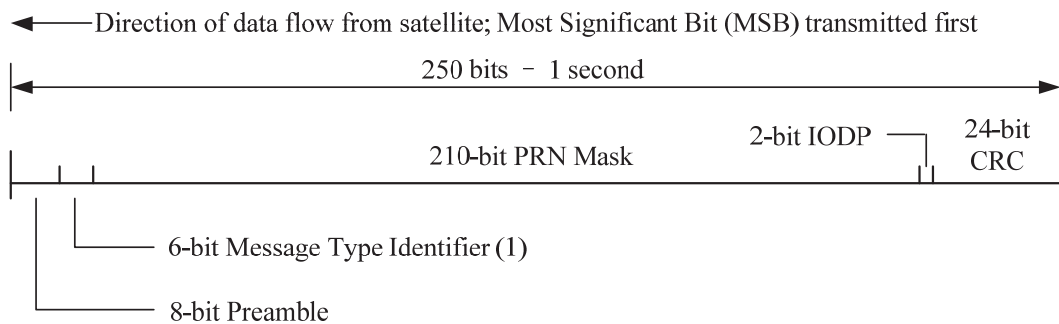

Figure 5-3 Message Type 1

210-bit data field consists of 210 PRN masks, each of which indicates if data is provided for the corresponding satellite as defined in Table 5-2. PRN mask is 1 meaning that the corresponding satellite is monitored by BDSBAS; otherwise, that satellite isn't monitored by BDSBAS. The number of PRN mask equaling 1 is the PRN Mask Number, which indicates

the order of monitored satellites in other messages. An example of the relationship among PRN mask, PRN code number and PRN mask number is shown in Figure 5-4.

210-bit Number	1	2	3	4	5	6	7	...	38	...	209	210									
PRN Mask	<table border="1"> <tr> <td>0</td> <td>0</td> <td>1</td> <td>0</td> <td>1</td> <td>0</td> <td>1</td> </tr> </table>							0	0	1	0	1	0	1	10 "0" s 20 "1" s	<table border="1"> <tr> <td>1</td> <td>...</td> <td>0</td> <td>0</td> </tr> </table>		1	...	0	0
0	0	1	0	1	0	1															
1	...	0	0																		
PRN Code Number	1	2	3	4	5	6	7	...	38	...	209	210									
PRN Mask Number			1		2		3	...	24	...											

Figure 5-4 An example of the relationship among PRN mask, PRN code number and PRN mask number

Table 5-2 PRN Mask Assignments

PRN Slot	Assignment
1-37	GPS
38-61	GLONASS
62-119	Future GNSS
120-158	GEO/SBAS PRN
159-210	Future GNSS

The transition of the PRN Mask to a new one (which will be infrequent) will be controlled with the 2-bit IODP, which will sequence to a number between 0 and 3. The same IODP will appear in the applicable Message Types 2-5, 7, 24, 25 and 28. If the IODP in Message Types 2-5, 7, 24, 25 and 28 does not equal to the one in Message Type 1, the user will not use the applicable message until a mask with the matching IODPs agree. During a change-over of the IODP in the PRN mask, the user equipment continues to use the old mask to decode messages until a corrections message using the new mask is received, and stores the new mask so that there are no interruptions to service when the new mask becomes effective.

### 5.3.3 Message Types 2-5

Message Types 2-5 contain the fast corrections, and the message format is illustrated in Figure 5-5.

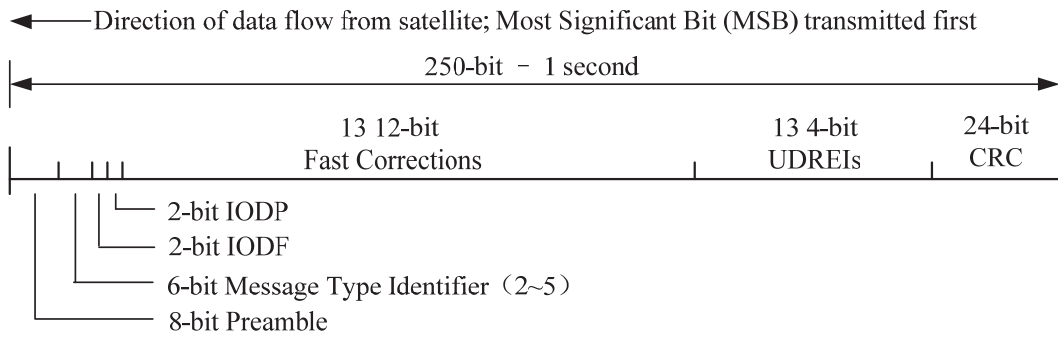

Figure 5-5 Message Types 2-5

Message Types 2-5 contain a 2-bit IODF<sub>j</sub>. The IODF<sub>j</sub>, where j is the fast corrections Message Type (2-5), is used to associate the UDRE Indicator (UDREI) contained in a Message Type 6. When there is no alert condition for any of the satellites in a Message Types 2-5, the range of each IODF<sub>j</sub> counter is only 0 to 2. When an alert occurs in one or more of the satellites in a Message Types 2-5, IODF<sub>j</sub>=3. The IODP in Message Types 2-5 should be same as the one in Message Type 1.

Message Type 2 contains the data sets for the first 13 satellites designated in the PRN mask. Message Type 3 contains the data sets for satellites 14-26 designated in the PRN mask. Message Type 4 contains the data sets for satellites 27-39 designated in the PRN mask. And Message Type 5 contains the data sets for satellites 40-51 designated in the PRN mask. In Message Types 2-5, the fast data for each satellite is 16-bit, including a 12-bit fast correction and a 4-bit UDREI. The evaluation of UDREI is listed in Table 5-3.

Table 5-3 Evaluation of UDREI

UDREI	UDRE (m)	$\sigma^2_{UDRE} (m^2)$
0	0.75	0.0520
1	1.0	0.0924
2	1.25	0.1444
3	1.75	0.2830
4	2.25	0.4678
5	3.0	0.8315
6	3.75	1.2992
7	4.5	1.8709
8	5.25	2.5465
9	6.0	3.3260
10	7.5	5.1968
11	15.0	20.7870



UDREI	UDRE (m)	$\sigma^2_{UDRE} (m^2)$
12	50.0	230.9661
13	150.0	2078.695
14	Not Monitored	Not Monitored
15	Do Not Use	Do Not Use

The 12-bit fast correction ( $PRC_f$ ) has a 0.125m resolution, for a valid range of -256.000m to +255.875m. If the range is exceeded, a “Do Not Use” indication will be inserted into the UDREI field (UDREI=15). The time of applicability ( $t_{of}$ ) of the  $PRC_f$  is the start of the epoch of the SNT second that is coincident with the transmission at the GEO satellite of the first bit of the message block.

The user will compute the current  $PRC(t)$  by using the  $PRC(t_{of})$ , which is applied as

$$PRC(t) = PRC(t_{of}) + RRC(t_{of}) \times (t - t_{of}) \quad (5-1)$$

If  $ai \neq 0$  (broadcast by Message Type 7), the RRC is computed by the user differencing fast corrections:

$$RRC(t_{of}) = \frac{PRC_{current} - PRC_{previous}}{\Delta t} \quad (5-2)$$

where,  $PRC_{current}$  is the most recent fast correction (broadcast by Message Types 2-5 and 24);  $PRC_{previous}$  is a previous fast correction (broadcast by Message Types 2-5 and 24);  $\Delta t = (t_{of} - t_{of,previous})$ ;  $t_{of}$  is time of applicability of  $PRC_{current}$ ;  $t_{of,previous}$  is time of applicability of  $PRC_{previous}$ .

If  $ai = 0$  (broadcast by Message Type 7),  $RRC(t_{of}) = 0$ .

Then add the  $PRC(t)$  to the pseudo-range measurement through Equation (5-3).

$$PR_{corrected}(t) = PR_{measured}(t) + PRC(t) \quad (5-3)$$

where,  $PR_{measured}(t)$  is the pseudo-range measurement at time  $t$ ,  $PR_{corrected}(t)$  is the measurement corrected by the fast corrections.

### 5.3.4 Message Type 6

Message Type 6 contains integrity information (only UDRE without GIVE), and the message format is illustrated in Figure 5-6. Message Type 6 includes 4 2-bit IODFs for each fast corrections Message Types 2-5. The remaining 204 bits are divided into 51 slots of 4-bit UDREIs, one for each satellite in the mask. The evaluation of UDREI is listed in Table 5-3.

For example, if  $IODF_3=1$ , then the UDREI for satellites 14-26 apply to the corrections provided in a previously broadcast Message Type 3 that had the  $IODF=1$ .

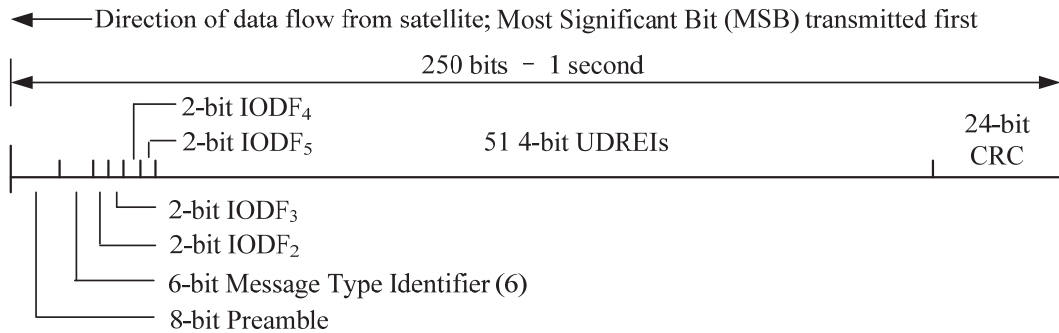

Figure 5-6 Message Type 6

### 5.3.5 Message Type 7

Message Type 7 specifies the applicable IODP, system latency time ( $t_{lat}$ ) and the UDRE degradation factor indicator ( $ai_i$ ) for computing the degradation of fast and long-term corrections, the message format is shown in Figure 5-7.

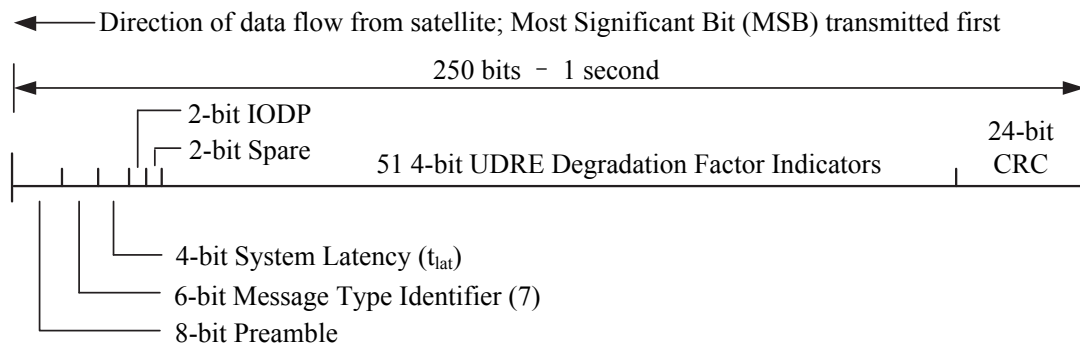

Figure 5-7 Message Type 7

Message Type 7 is to allow users to estimate the current accuracy and integrity by using the old-but-active corrections and integrity information when they do not receive the latest information. The IODP in Message Type 7 should be same as the one in Message Type 1, and the UDRE degradation factor indicators are determined by the PRN mask number of Message Type 1. The UDRE degradation factor and user time-out interval evaluation are listed in Table 5-4. The time-out interval for fast corrections is reckoned from the end of reception of the fast correction message.

Table 5-4 UDRE Degradation Factor and User Time-Out Interval Evaluation

<b>UDRE Degradation Factor Indicator</b>	<b>UDRE Degradation Factor (m/s<sup>2</sup>)</b>	<b>User Time-Out Interval for Fast Corrections – seconds En Route through LNAV Approach (<math>I_{fc}</math>)</b>	<b>User Time-Out Interval for Fast Corrections – seconds LNAV/VNAV, LPV, LP Approach (<math>I_{fc}</math>)</b>	<b>Maximum Fast Correction Update Interval (seconds)</b>
0	0.00000	180	120	60
1	0.00005	180	120	60
2	0.00009	153	102	51
3	0.00012	135	90	45
4	0.00015	135	90	45
5	0.00020	117	78	39
6	0.00030	99	66	33
7	0.00045	81	54	27
8	0.00060	63	42	21
9	0.00090	45	30	15
10	0.00150	45	30	15
11	0.00210	27	18	9
12	0.00270	27	18	9
13	0.00330	27	18	9
14	0.00460	18	12	6
15	0.00580	18	12	6

### 5.3.6 Message Type 9

Message Type 9 contains GEO satellite ephemeris representing the position, velocity and acceleration of the geostationary satellite, in ECEF Coordinates, and its apparent clock time and frequency offsets. It also includes the time of applicability ( $t_0$ ) and an accuracy exponent (URA) representing the health of the GEO ranging signal.  $a_{Gf0}$  and  $a_{Gf1}$  will be the estimate of the time offset and drift with respect to BDSBAS SNT. The message format and parameters are shown in Figure 5-8 and Table 5-5, respectively.

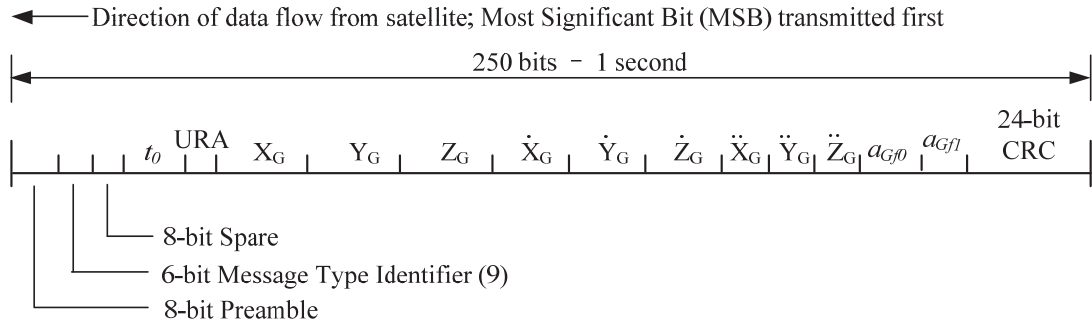

Figure 5-8 Message Type 9

Table 5-5 Message Type 9 Parameters

Parameter	No. of Bits	Scale Factor (LSB)	Effective Range	Units
Reserved	8	--	--	--
$t_0$	13	16	0-86384	s
URA	4	--	--	unitless
$X_G$ (ECEF)	30	0.08	$\pm 42,949,673$	m
$Y_G$ (ECEF)	30	0.08	$\pm 42,949,673$	m
$Z_G$ (ECEF)	25	0.4	$\pm 6,710,886.4$	m
$X_G$ Rate of Change	17	0.000625	$\pm 40.96$	m/s
$Y_G$ Rate of Change	17	0.000625	$\pm 40.96$	m/s
$Z_G$ Rate of Change	18	0.004	$\pm 524.288$	m/s
$X_G$ Acceleration	10	0.0000125	$\pm 0.0064$	$m/s^2$
$Y_G$ Acceleration	10	0.0000125	$\pm 0.0064$	$m/s^2$
$Z_G$ Acceleration	10	0.0000625	$\pm 0.032$	$m/s^2$
$a_{Gf0}$	12	$2^{-31}$	$\pm 0.9537 \times 10^{-6}$	s
$a_{Gf1}$	8	$2^{-40}$	$\pm 1.1642 \times 10^{-10}$	s/s

The position and time of the GEO will be propagated to time-of-day  $t$  as:

$$t = t_G - \Delta t_G = t_G - [a_{Gf0} + a_{Gf1}(t_G - t_0)] \quad (5-4)$$

$$\begin{bmatrix} X_{GK} \\ Y_{GK} \\ Z_{GK} \end{bmatrix} = \begin{bmatrix} X_G \\ Y_G \\ Z_G \end{bmatrix} + \begin{bmatrix} \dot{X}_G \\ \dot{Y}_G \\ \dot{Z}_G \end{bmatrix} (t-t_0) + \frac{1}{2} \begin{bmatrix} \ddot{X}_G \\ \ddot{Y}_G \\ \ddot{Z}_G \end{bmatrix} (t-t_0)^2 \quad (5-5)$$

where,  $t_G$  is the (uncorrected) time at which the signal left the GEO, expressed in that GEO's reference time;  $t_0$  is the time of applicability of the message;  $[X_{GK} \ Y_{GK} \ Z_{GK}]^T$  is the location of GEO at  $t$ ;  $[X_G \ Y_G \ Z_G]^T$  is the location of GEO at  $t_0$ ;  $[\dot{X}_G \ \dot{Y}_G \ \dot{Z}_G]^T$  is the rate of change at  $t_0$ ;  $[\ddot{X}_G \ \ddot{Y}_G \ \ddot{Z}_G]^T$  is the acceleration at  $t_0$ ;  $a_{Gf0}$  and  $a_{Gf1}$  are the time offset and drift.

### 5.3.7 Message Type 10

Message Type 10 contains degradation parameters, the message format and 210-bit data field are shown in Figure 5-9 and Table 5-6, respectively.

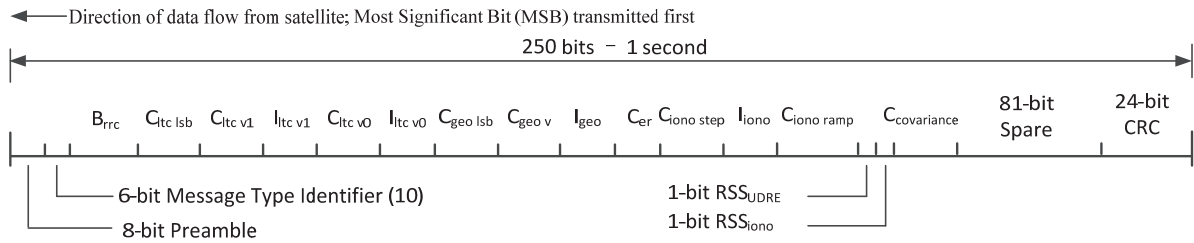

Figure 5-9 Message Type 10

Table 5-6 Message Type 10 Degradation Parameters

Parameter	No. of Bits	Scale Factor (LSB)	Effective Range	Units
$B_{rrc}$	10	0.002	0-2.046	m
$C_{ltc\ lsb}$	10	0.002	0-2.046	m
$C_{ltc\ v1}$	10	0.00005	0-0.05115	m/s
$I_{ltc\ v1}$	9	1	0-511	s
$C_{ltc\ v0}$	10	0.002	0-2.046	m
$I_{ltc\ v0}$	9	1	0-511	s
$C_{geo\ lsb}$	10	0.0005	0-0.5115	m
$C_{geo\ v}$	10	0.00005	0-0.05115	m/s
$I_{geo}$	9	1	0-511	s
$C_{er}$	6	0.5	0-31.5	m
$C_{iono\ step}$	10	0.001	0-1.023	m
$I_{iono}$	9	1	0-511	s
$C_{iono\ ramp}$	10	0.000005	0-0.005115	m/s
RSS <sub>UDRE</sub>	1	--	0-1	unitless
RSS <sub>iono</sub>	1	--	0-1	unitless
$C_{covariance}$	7	0.1	0-12.7	unitless
Spare	81	--	--	--

### 5.3.8 Message Type 12

Message Type 12 contains the offset parameters of BDSBAS SNT and UTC. It consists of the 8-bit preamble, a 6-bit message type identifier followed by 104 information bits for the UTC parameters, then followed by 3-bit to indicate the UTC time standard from which the offset is determined. The next 20-bit is the GPS Time of Week (TOW) in seconds of the beginning of the message, followed by a 10-bit GPS Week Number (WN). The final 75 bits

are spare bits. The message format and parameters are shown in Figure 5-10 and Table 5-7, respectively.

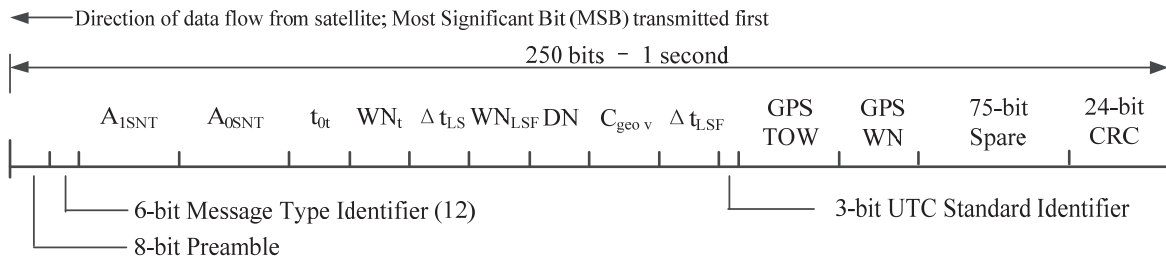

Figure 5-10 Message Type 12

Table 5-7 Message Type 12 Parameters

Parameter	No. of Bits	Scale Factor (LSB)	Effective Range	Units
$A_{1SNT}$	24	$2^{-50}$	$\pm 7.45 \times 10^{-9}$	s/s
$A_{0SNT}$	32	$2^{-30}$	$\pm 1$	s
$t_{0t}$	8	$2^{12}$	0-602,112	s
$WN_t$	8	1	0-255	week
$\Delta t_{LS}$	8	1	$\pm 128$	s
$WN_{LSF}$	8	1	0-255	week
DN	8	1	1-7	day
$\Delta t_{LSF}$	8	1	$\pm 128$	s
UTC standard Identifier	3	--	--	unitless
TOW	20	1	0-604,799	s
WN	10	1	0-1023	week

Table 5-8 UTC Standard Identifier

UTC Identifier	UTC Standard
0	Japanese National Institute of Information and Communications Technology, NICT
1	U. S. National Institute of Standards and Technology, NIST
2	U. S. Naval Observatory, USNO
3	International Bureau of Weights and Measures, BIPM
4	European Laboratory (TBD)
5	National Time Service Center Chinese Academy of Sciences, NTSC
6	Reserved for future definition
7	UTC not provided

The time offset between SNT and UTC can be calculated as below:

$$\Delta t_{UTC} = \Delta t_{LS} + A_{0SNT} + A_{1SNT} [t - t_{0t} + 604800(WN - WN_t)] \quad (5-6)$$

where,  $WN_t$  and  $t_{0t}$  are the week number and time of week of UTC, respectively;  $WN$  and  $t$  are the current week number and time of week, respectively;  $A_{0SNT}$  and  $A_{1SNT}$  are the constant and first order terms of polynomial;  $\Delta t_{LS}$  is the delta time due to leap seconds.

### 5.3.9 Message Type 17

Almanacs for GEOs will be broadcast periodically to alert the user of their existence, location, health and status. The message format and parameters are shown in Figure 5-11 and Table 5-9, respectively. Unused almanacs will have a PRN number of 0 and should be ignored.

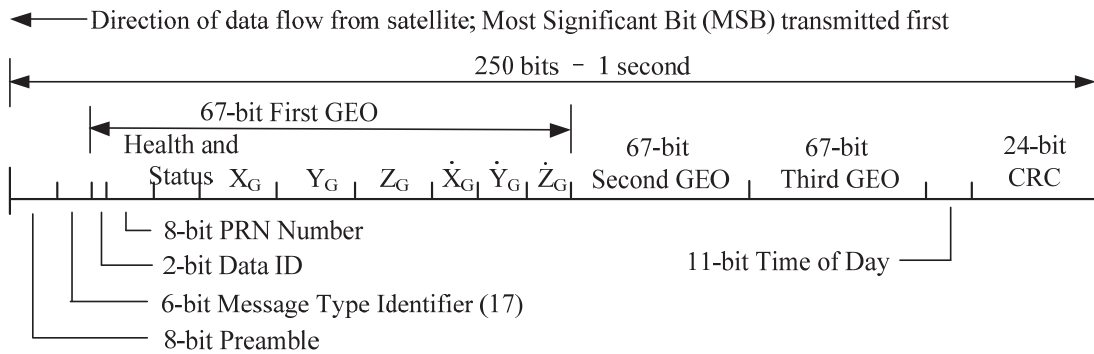

Figure 5-11 Message Type 17

Table 5-9 Message Type 17 Parameters

Parameter	No. of Bits	Scale Factor (LSB)	Effective Range	Units
For each of 3 satellites	67	--	--	--
Data ID	2	1	0-3	unitless
PRN Number	8	1	0-210	unitless
Health and Status (Table 5-10)	8	--	--	--
$X_G$ (ECEF)	15	2,600	$\pm 42,595,800$	m
$Y_G$ (ECEF)	15	2,600	$\pm 42,595,800$	m
$Z_G$ (ECEF)	9	26,000	$\pm 6,630,000$	m
$X_G$ Rate of Change	3	10	$\pm 40$	m/s
$Y_G$ Rate of Change	3	10	$\pm 40$	m/s
$Z_G$ Rate of Change	4	60	$\pm 480$	m/s
$t_0$ (Time of Day)	11	64	0-86,336	s

Table 5-10 Definition of 8-bit Health and Status

Bit (LSB)	Meaning	Set to 0	Set to 1
0	Ranging	On	Off
1	Precision Corrections	On	Off
2	Satellite Status and Basic Corrections	On	Off
3	Reserved	--	--
4-7	Service Provider ID (Table 5-11)	--	--

Table 5-11 Definition of Service Provider ID

ID	Service Provider
0	WAAS
1	EGNOS
2	MSAS
3	GAGAN
4	SDCM
5	BDSBAS
6	KASS
7	A-SBAS
8	SPAN
9-13	Not Yet Assigned
14-15	Reserved

The position of the GEO will be propagated to time-of-day  $t$  as:

$$\begin{bmatrix} X_{GK} \\ Y_{GK} \\ Z_{GK} \end{bmatrix} = \begin{bmatrix} X_G \\ Y_G \\ Z_G \end{bmatrix} + \begin{bmatrix} \dot{X}_G \\ \dot{Y}_G \\ \dot{Z}_G \end{bmatrix} (t - t_0) \quad (5-7)$$

where,  $t_0$  is the time of applicability of the message;  $[X_{GK} \ Y_{GK} \ Z_{GK}]^T$  is the location of GEO at  $t$ ;  $[X_G \ Y_G \ Z_G]^T$  is the location of GEO at  $t_0$ ;  $[\dot{X}_G \ \dot{Y}_G \ \dot{Z}_G]^T$  is the rate of change at  $t_0$ .

### 5.3.10 Message Type 18

Message Type 18 contains Ionospheric Grid Point (IGP) masks, message format is shown in Table 5-12.



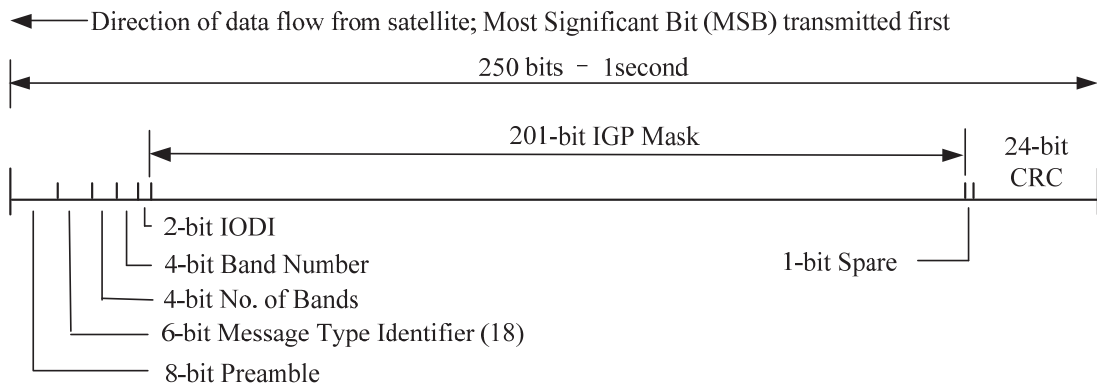

Figure 5-12 Message Type 18

The predefined IGPs are contained in 11 bands (numbered 0 to 10). Bands 0-8 are vertical bands on a Mercator projection map, and bands 9-10 are horizontal bands on a Mercator projection map. The density of these predefined IGPs, given in Table 5-12 for bands 0-8 and Table 5-13 for bands 9-10. There are total 2192 IGPs, these IGP locations must be stored permanently by the user. If the IGP mask is 1, it indicates that the IGP is effective, and corresponding ionospheric delay information will be broadcast in Message Type 26. Otherwise, the IGP is not effective. The users only use the IGPs with mask=1.

Table 5-12 IGP Bands 0-8

Latitudes (degrees)	Latitude Spacing (degrees)	Longitude Spacing (degrees)
N85	10	90
N75 to N65	10	10
S55 to N55	5	5
S75 to S65	10	10
S85	10	90

Table 5-13 IGP Bands 9-10

Latitudes (degrees)	Latitude Spacing (degrees)	Longitude Spacing (degrees)
N85	10	30
N75 to N65	5	10
N60	5	5
S60	5	5
S75 to S65	5	10
S85	10	30

Within bands 0 through 7, the IGPs are numbered from 1 to 201. Within band 8, the IGPs are numbered from 1 through 200. Within bands 9 and 10, the IGPs are numbered from 1

through 192. In bands 0 to 8, the IGP are numbered counting up from the southwest corner (bottom-left) up each longitude column of the band (from south to north) and continuing for each column from west to east (left-to-right) from the bottom of each column. In bands 9 and 10, the IGP are numbered counting eastward from the western corner closest to the equator along each latitude row of the band (from west to east) and continuing for each row towards the poles.

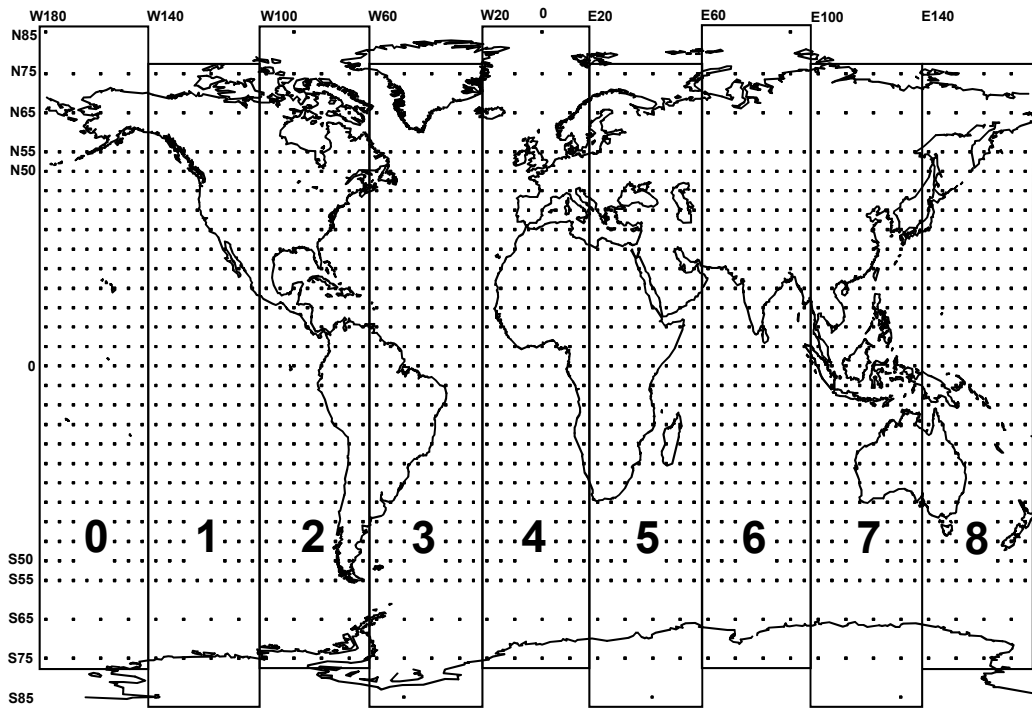

Figure 5-13 Predefined Global IGP Grid

### 5.3.11 Message Type 24

Message Type 24 contains mixed fast corrections/long term satellite error corrections, and message format is shown in Figure 5-14.

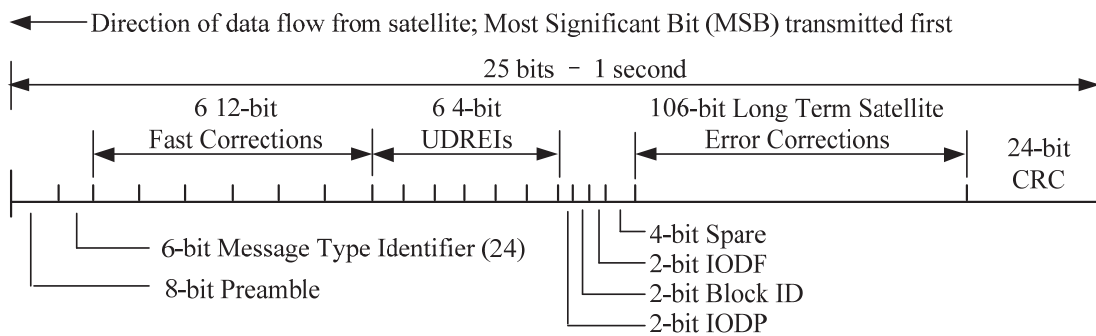

Figure 5-14 Message Type 24

The first half of the message consists of six fast data sets according to the PRN mask sequence, followed by the 2-bit IODP, a 2-bit Block ID indicating which corrections block is provided, and the 2-bit IODF, leaving 4 spare bits, for a total of 106 bits. The Block ID (0, 1, 2, 3) will indicate whether the Message Type 24 contains the fast corrections associated with a Message Type 2, Message Type 3, Message Type 4, or Message Type 5, respectively. The final 106 bits of the data field are composed of a 106-bit half message as described in Message Type 25.

### 5.3.12 Message Type 25

Message Type 25 will be broadcast to provide error estimates for slow varying satellite ephemeris and clock errors. 212-bit data field of Message Type 25 are split into two 106-bit parts, these two parts have the same definition. The following focuses on the definition of the first 106-bit data field. The first bit of 106-bit data field is velocity code, and the definition of the last 105-bit is depending on the velocity code. When the velocity code is 0 or 1, the definitions of Message Type 25 are shown in Figure 5-15 and Figure 5-16, respectively. Message Type 25 can consist of error estimates for 1, 2, 3 or 4 satellites, depending upon the velocity codes in both halves of the message and how many satellites are being corrected.

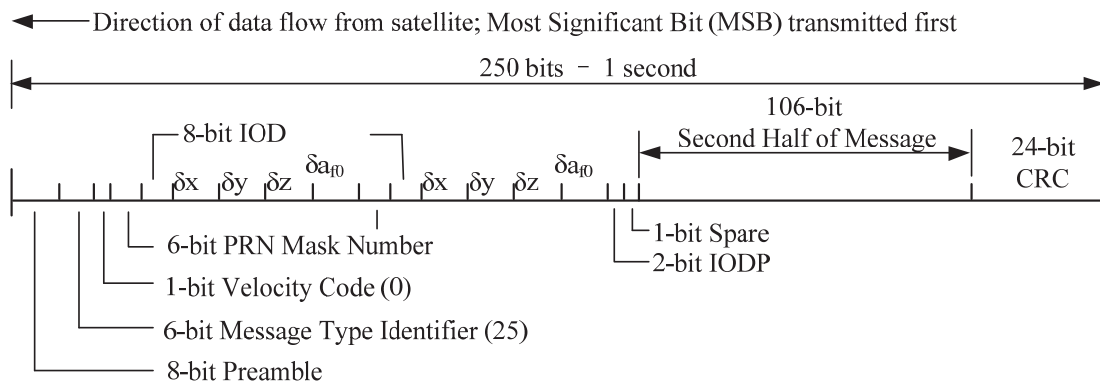

Figure 5-15 Message Type 25 with Velocity Code=0

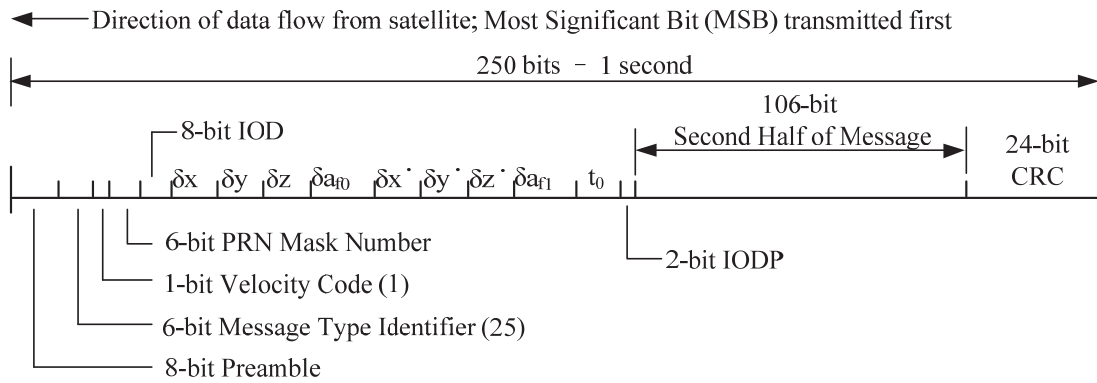

Figure 5-16 Message Type 25 with Velocity Code=1

When the velocity code is 0, the first half of Message Type 25 message contains the corrections for the long-term satellite position and clock offset errors of two satellites, without velocity and clock drift errors. The definition of 106-bit with velocity code=0 is listed in Table 5-14.

Table 5-14 Definition of 106-bit with Velocity Code=0

Parameter	No. of Bits	Scale Factor(LSB)	Effective Range	Units
Velocity Code=0	1	1	--	unitless
PRN Mask No.	6	1	0-51	unitless
IOD	8	1	0-255	unitless
$\Delta x$ (ECEF)	9	0.125	$\pm 32$	m
$\Delta y$ (ECEF)	9	0.125	$\pm 32$	m
$\Delta z$ (ECEF)	9	0.125	$\pm 32$	m
$\delta a_{f0}$	10	$2^{-31}$	$\pm 2^{-22}$	s
PRN Mask No.	6	1	0-51	unitless
IOD	8	1	0-255	unitless
$\Delta x$ (ECEF)	9	0.125	$\pm 32$	m
$\Delta y$ (ECEF)	9	0.125	$\pm 32$	m
$\Delta z$ (ECEF)	9	0.125	$\pm 32$	m
$\delta a_{f0}$	10	$2^{-31}$	$\pm 2^{-22}$	s
IODP	2	1	0-3	unitless
Spare	1	--	--	--

When the velocity code is 1, the first half of Message Type 25 message contains the corrections for the long-term satellite position, velocity, clock offset and drift errors of one satellite. The definition of 106-bit with velocity code=1 is listed in Table 5-15.

Table 5-15 Definition of 106-bit with Velocity Code=1

Parameter	No. of Bits	Scale Factor (LSB)	Effective Range	Units
Velocity Code=1	1	1	--	unitless
PRN Mask No.	6	1	0-51	unitless
IOD	8	1	0-255	unitless
$\Delta x$ (ECEF)	11	0.125	$\pm 128$	m
$\Delta y$ (ECEF)	11	0.125	$\pm 128$	m
$\Delta z$ (ECEF)	11	0.125	$\pm 128$	m
$\delta a_{f0}$	11	$2^{-31}$	$\pm 2^{-21}$	s
$\delta x$ rate-of-change (ECEF)	8	$2^{-11}$	$\pm 0.0625$	m/s
$\delta y$ rate-of-change (ECEF)	8	$2^{-11}$	$\pm 0.0625$	m/s
$\delta z$ rate-of-change (ECEF)	8	$2^{-11}$	$\pm 0.0625$	m/s
$\delta a_{f1}$	8	$2^{-39}$	$\pm 2^{-32}$	s/s
Time-of-Day Applicability $t_0$	13	16	0-86384	s
IODP	2	1	0-3	unitless

The computation of the clock time error estimate  $\delta\Delta t_{SV}$  at time-of-day  $t$  as:

$$\delta\Delta t_{SV}(t) = \delta a_{f0} + \delta a_{f1}(t - t_0) + \delta a_{fG0} \quad (5-8)$$

where,  $\delta a_{f0}$  is the clock offset error correction;  $\delta a_{f1}$  is the clock drift error correction (when velocity code=0,  $\delta a_{f1}=0$ );  $t_0$  is the time of day applicability;  $\delta a_{fG0}$  is an additional correction for the GLONASS satellites provided in Message Type 12, and it is set to 0 for non GLONASS satellites.

The computation of the position error correction vector (WGS-84 ECEF) at time-of-day  $t$  as:

$$\begin{bmatrix} \delta x_k \\ \delta y_k \\ \delta z_k \end{bmatrix} = \begin{bmatrix} \delta x \\ \delta y \\ \delta z \end{bmatrix} + \begin{bmatrix} \delta \dot{x} \\ \delta \dot{y} \\ \delta \dot{z} \end{bmatrix} (t - t_0) \quad (5-9)$$

When velocity code=0, the velocity vector in Equation (5-9) is 0.

### 5.3.13 Message Type 26

Message Type 26 contains ionospheric delay corrections and their accuracy (GIVEI) at geographically defined IGPs, and the message format is shown in Figure 5-17.

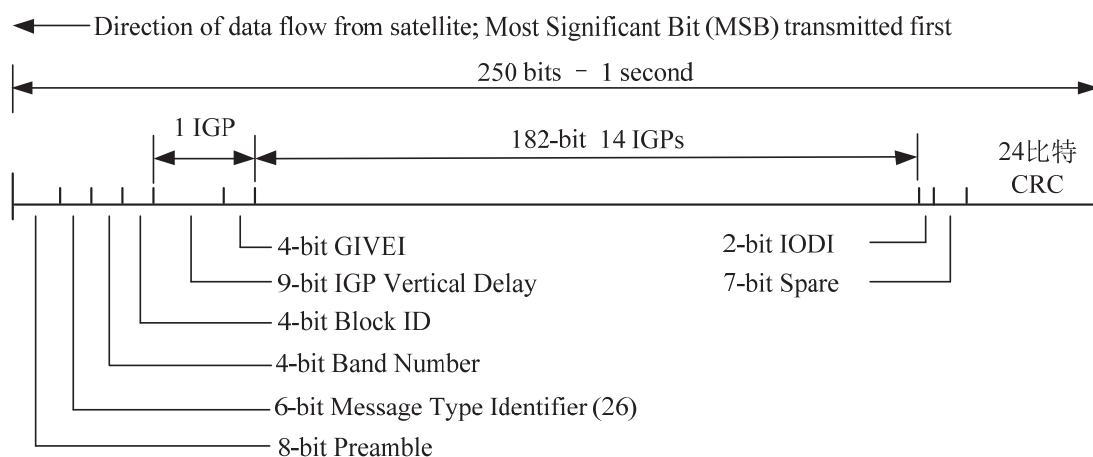

Figure 5-17 Message Type 26

Each message contains a band number and a block ID that indicates the location of the IGPs in the respective band mask, following is the data field which can store IGP corrections and GIVEI for 15 IGPs in the band mask. The definitions of Message Type 26 Parameters are listed in Table 5-16.

Table 5-16 Message Type 26 Parameters

Parameter	No. of Bits	Scale Factor (LSB)	Effective Range	Units
Band Number	4	1	0-10	unitless
Block ID	4	1	0-13	unitless
For Each of 15 Grid Points	13	--	--	--
IGP Vertical Delay Estimate	9	0.125	0-63.875	m
GIVEI	4	1	0-15	unitless
IODI	2	1	0-3	unitless
Spare	7	--	--	--

The 9-bit IGP vertical delays have a 0.125m resolution, for a 0-63.750m valid range. A vertical delay of “11111111” will indicate “don't use” for that IGP. The evaluation of GIVEI is shown in Table 5-17.

Table 5-17 Evaluation of GIVEI

GIVEI	GIVE (m)	$\sigma^2_{GIVE} (m^2)$
0	0.3	0.0084
1	0.6	0.0333
2	0.9	0.0749
3	1.2	0.1331
4	1.5	0.2079

GIVEI	GIVE (m)	$\sigma^2_{GIVE} (m^2)$
5	1.8	0.2994
6	2.1	0.4075
7	2.4	0.5322
8	2.7	0.6735
9	3.0	0.8315
10	3.6	1.1974
11	4.5	1.8709
12	6.0	3.3260
13	15.0	20.7870
14	45.0	187.0826
15	Not Monitored	Not Monitored

The ionospheric correction processing flow is shown in Figure 5-18.

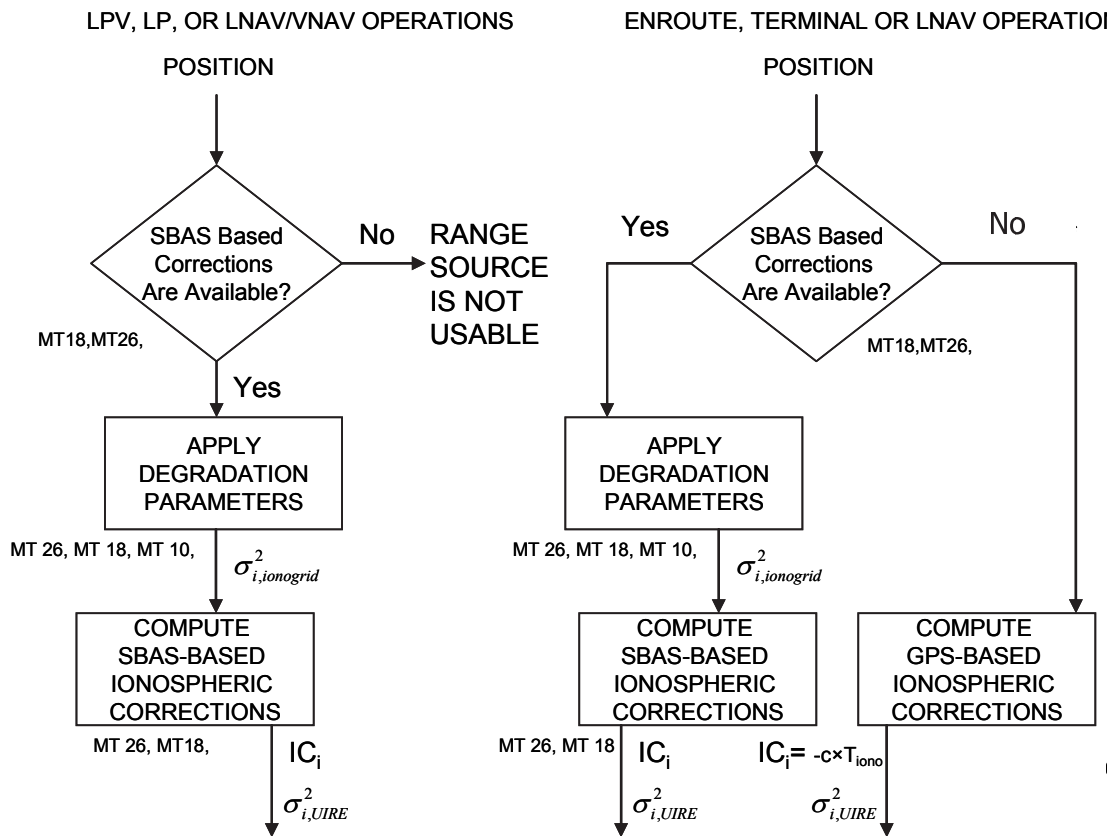

Figure 5-18 Ionospheric Correction Processing Flow

### 5.3.13.1 Pierce Point Location Determination

First, the latitude of ionospheric pierce point (IPP)  $\phi_{pp}$  is computed as:

$$\phi_{pp} = \sin^{-1}(\sin \phi_u \cos \psi_{pp} + \cos \phi_u \sin \psi_{pp} \cos A) \quad (5-10)$$

$$\psi_{pp} = \frac{\pi}{2} - E - \sin^{-1} \left( \frac{R_e}{R_e + h_I} \cos E \right) \quad (5-11)$$

where,  $\psi_{pp}$  is the earth's central angle between the user position and the earth projection of the pierce point;  $A$  is the azimuth angle of the satellite from the user's location;  $E$  is the elevation angle of the satellite from the user's location;  $R_e$  is the approximate radius of the earth's ellipsoid (taken to be 6378.1363km);  $h_I$  is the height of the maximum electron density (taken to be equal to 350km).

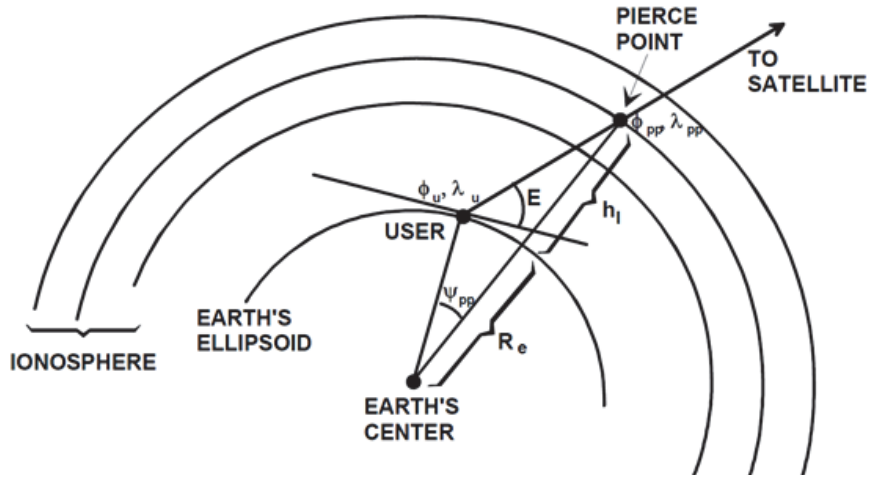

Figure 5-19 Ionospheric Pierce Point Geometry

The longitude of the IPP  $\lambda_{pp}$  is:

(1) If  $\phi_u > 70^\circ$ , and  $\tan \psi_{pp} \cos A > \tan(\pi/2 - \phi_u)$ , or if  $\phi_u < -70^\circ$ , and  $\tan \psi_{pp} \cos(A + \pi) > \tan(\pi/2 + \phi_u)$

$$\lambda_{pp} = \lambda_u + \pi - \sin^{-1} \left( \frac{\sin \psi_{pp} \sin A}{\cos \phi_{pp}} \right) \quad (5-12)$$

(2) Otherwise,

$$\lambda_{pp} = \lambda_u + \sin^{-1} \left( \frac{\sin \psi_{pp} \sin A}{\cos \phi_{pp}} \right) \quad (5-13)$$

### 5.3.13.2 Selection of Ionospheric Grid Points

After determining the location of the user ionospheric pierce point, the user must select the IGPs to be used to interpolate the ionospheric correction and model variance. This selection is done based only on the information provided in the mask, and must be done without regard to whether or not the selected IGPs are monitored, not monitored, or don't use. The selection process will take place as described below.



(1) For an IPP between  $N60^\circ$  and  $S60^\circ$  :

- if four IGPs that define a  $5^\circ \times 5^\circ$  cell around the IPP are set to one in the IGP mask, they are selected; else,
- if any three IGPs that define a  $5^\circ \times 5^\circ$  triangle that circumscribes the IPP are set to one in the IGP mask, they are selected; else,
- if any four IGPs that define a  $10^\circ \times 10^\circ$  cell around the IPP are set to one in the IGP mask, they are selected; else,
- if any three IGPs that define a  $10^\circ \times 10^\circ$  triangle that circumscribes the IPP are set to one in the IGP mask, they are selected; else, an ionospheric correction is not available.

(2) For an IPP between  $N60^\circ$  and  $N75^\circ$  or between  $S60^\circ$  and  $S75^\circ$  :

- if four IGPs that define a  $5^\circ(\text{latitude}) \times 10^\circ(\text{longitude})$  cell around the IPP are set to one in the IGP mask, they are selected; else,
- if any three IGPs that define a  $5^\circ(\text{latitude}) \times 10^\circ(\text{longitude})$  triangle that circumscribes the IPP are set to one in the IGP mask, they are selected; else,
- if any four IGPs that define a  $10^\circ \times 10^\circ$  cell around the IPP are set to one in the IGP mask, they are selected; else,
- if any three IGPs that define a  $10^\circ \times 10^\circ$  triangle that circumscribes the IPP are set to one in the IGP mask, they are selected; else, an ionospheric correction is not available.

(3) For an IPP between  $N75^\circ$  and  $N85^\circ$  or between  $S75^\circ$  and  $S85^\circ$  :

- if the two nearest IGPs at  $75^\circ$  and the two nearest IGPs at  $85^\circ$  (separated by  $30^\circ$  longitude if Band 9 or 10 is used, separated by  $90^\circ$  otherwise) are set to one in the IGP mask, a  $10^\circ \times 10^\circ$  cell is created by linearly interpolating between the IGPs at  $85^\circ$  to obtain virtual IGPs at longitudes equal to the longitudes of the IGPs at  $75^\circ$  ; else, an ionospheric correction is not available.

(4) For an IPP north of  $N85^\circ$  :

- if the four IGPs at  $N85^\circ$  latitude and longitudes of  $W180^\circ$  ,  $W90^\circ$  ,  $0^\circ$  and  $E90^\circ$  are set to one in the IGP mask, they are selected; else, an ionospheric correction is not available.

(5) For an IPP south of  $S85^\circ$  :

- if the four IGPs at  $S85^\circ$  latitude and longitudes of  $W140^\circ$  ,  $W50^\circ$  ,  $E40^\circ$  and

E130° are set to one in the IGP mask, they are selected; else, an ionospheric correction is not available.

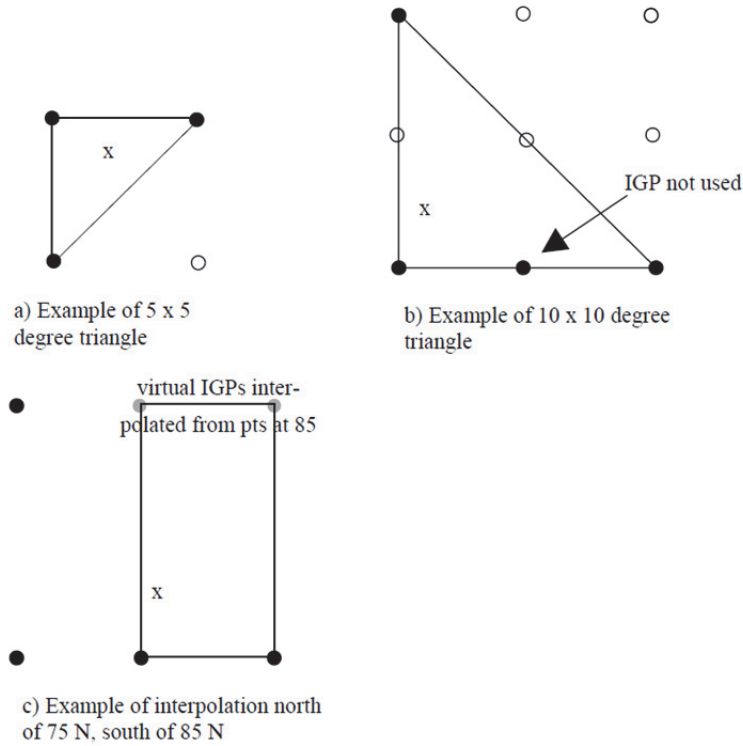

Figure 5-20 IGP Interpolation

### 5.3.13.3 Ionospheric Pierce Point Vertical Delay Calculation

Although the data broadcast to the user is in the form of vertical IGP delays, these points do not generally correspond with his computed IPP locations. Thus, it is necessary for the user to interpolate from the broadcast IGP delays to that at his computed IPP locations.

#### (1) Four-point interpolation

For four-point interpolation, the mathematical formulation for interpolated vertical IPP delay  $\tau_{vpp}(\phi_{pp}, \lambda_{pp})$  as a function of IPP latitude and longitude is

$$\tau_{vpp}(\phi_{pp}, \lambda_{pp}) = \sum_{i=1}^4 W_i(x_{pp}, y_{pp}) \tau_{vi} \quad (5-14)$$

where,  $\phi_{pp}$  and  $\lambda_{pp}$  are the latitude and longitude of IPP, respectively;  $\tau_{vi}$  are the broadcast grid point vertical delay values at four corners of the IGP grid;  $W_i(x_{pp}, y_{pp})$  are the weighting function of IGP grids.

$$W_1(x_{pp}, y_{pp}) = x_{pp} y_{pp} \quad (5-15)$$

$$W_2(x_{pp}, y_{pp}) = (1 - x_{pp})y_{pp} \quad (5-16)$$

$$W_3(x_{pp}, y_{pp}) = (1 - x_{pp})(1 - y_{pp}) \quad (5-17)$$

$$W_4(x_{pp}, y_{pp}) = x_{pp}(1 - y_{pp}) \quad (5-18)$$

$$\Delta\lambda_{pp} = \lambda_{pp} - \lambda_1 \quad (5-19)$$

$$\Delta\phi_{pp} = \phi_{pp} - \phi_1 \quad (5-20)$$

The definitions of four-point interpolation are shown in Figure 5-21.

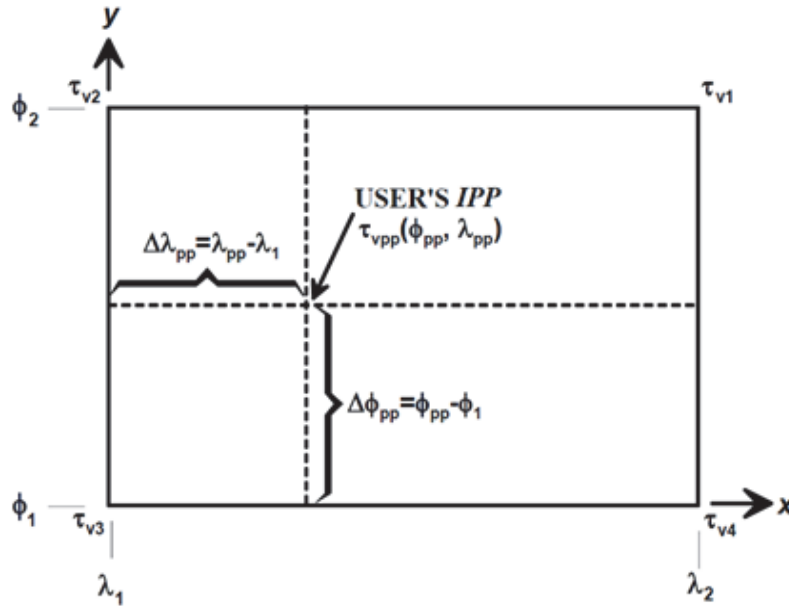

Figure 5-21 Four-Point Interpolation Definitions

For IPP's between N85° and S85° ,

$$x_{pp} = \frac{\Delta\lambda_{pp}}{\lambda_2 - \lambda_1} \quad (5-21)$$

$$y_{pp} = \frac{\Delta\phi_{pp}}{\phi_2 - \phi_1} \quad (5-22)$$

where,  $\lambda_1$  is longitude of IGPs west of IPP;  $\lambda_2$  is longitude of IGPs east of IPP;  $\phi_1$  is latitude of IGPs south of IPP;  $\phi_2$  is latitude of IGPs north of IPP.

For IPPs north of N85° or south of S85° ,

$$y_{pp} = \frac{|\phi_{pp}| - 85^\circ}{10^\circ} \quad (5-23)$$

$$x_{pp} = \frac{\lambda_{pp} - \lambda_3}{90^\circ} (1 - 2y_{pp}) + y_{pp} \quad (5-24)$$

where,  $\lambda_1$  is longitude of the second IGP to the east of the IPP;  $\lambda_2$  is longitude of the

second IGP to the west of the IPP;  $\lambda_3$  is longitude of the closest IGP to the west of the IPP;  $\lambda_4$  is longitude of the closest IGP to the east of the IPP.

The  $\sigma_{UIVE}^2$  will be interpolated by the users from the  $\sigma_{n,ionogrid}^2$ 's defined at the IGP to the IPP as follows:

$$\sigma_{UIVE}^2 = \sum_{n=1}^4 W_n(x_{pp}, y_{pp}) \sigma_{n,ionogrid}^2 \quad (5-25)$$

(2) Three-point interpolation

For three-point interpolation between S75° and N75°, a similar algorithm is used:

$$\tau_{vpp}(\phi_{pp}, \lambda_{pp}) = \sum_{i=1}^3 W_i(x_{pp}, y_{pp}) \tau_{vi} \quad (5-26)$$

where,  $\phi_{pp}$  and  $\lambda_{pp}$  are the latitude and longitude of IPP, respectively;  $\tau_{vi}$  are the broadcast grid point vertical delay values at four corners of the IGP grid;  $W_i(x_{pp}, y_{pp})$  are the weighting function of IGP grids.

$$W_1(x_{pp}, y_{pp}) = y_{pp} \quad (5-27)$$

$$W_2(x_{pp}, y_{pp}) = 1 - x_{pp} - y_{pp} \quad (5-28)$$

$$W_3(x_{pp}, y_{pp}) = x_{pp} \quad (5-29)$$

The definitions of three-point interpolation are shown in Figure 5-22:

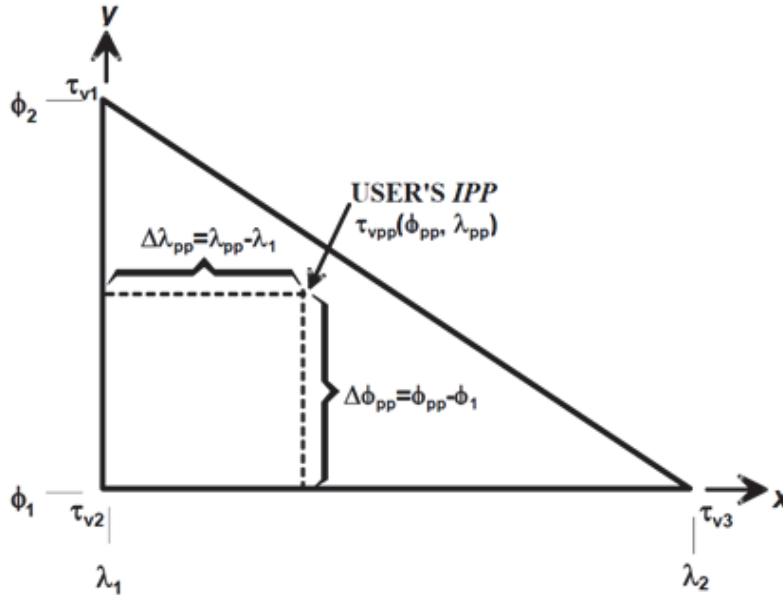

Figure 5-22 Three-Point Interpolation Definitions

The  $\sigma_{UIVE}^2$  will be interpolated by the users from the  $\sigma_{n,ionogrid}^2$ 's defined at the IGP to the IPP as follows:

$$\sigma_{UIVE}^2 = \sum_{n=1}^3 W_n (x_{pp}, y_{pp}) \sigma_{n,ionogrid}^2 \quad (5-30)$$

#### 5.3.13.4 Slant Ionospheric Delay Calculation

Once the user establishes the vertical delay at the pierce point, the user can then multiply that vertical delay by the obliquity factor to obtain the ionospheric correction ( $IC_i$ ) to be added to the pseudorange measurement:

$$IC_i = -\tau_{spp}(\phi_{pp}, \lambda_{pp}) = -F_{pp} \cdot \tau_{vpp}(\phi_{pp}, \lambda_{pp}) \quad (5-31)$$

where,  $\tau_{spp}(\phi_{pp}, \lambda_{pp})$  is the interpolated vertical delay at the user-to-satellite IPP derived as described above;  $F_{pp}$  is obliquity factor.

$$F_{pp} = \left[ 1 - \left( \frac{R_e \cos E}{R_e + h_t} \right)^2 \right]^{-\frac{1}{2}} \quad (5-32)$$

The  $\sigma_{UIRE}^2$  is computed as:

$$\sigma_{UIRE}^2 = F_{pp}^2 \cdot \sigma_{UIVE}^2 \quad (5-33)$$

#### 5.3.14 Message Type 28

Message Type 28 contains the clock-ephemeris covariance matrix for clock and ephemeris errors. The message format and parameters are shown in Table 5-23 and Table 5-18. The IODP in Message Type 28 should be same as the one in Message Type 1, and the PRN mask number is determined by Message Type 1.

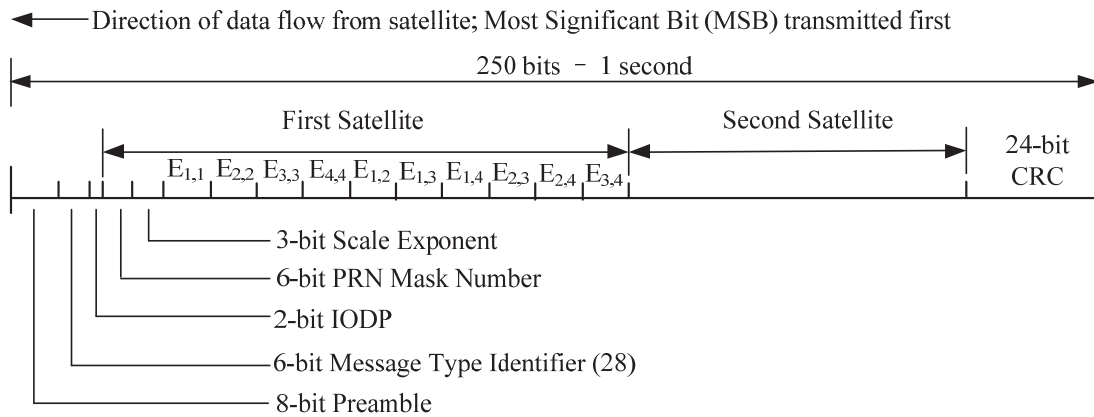

Figure 5-23 Message Type 28

Table 5-18 Message Type 28 Parameters

Parameter	No. of Bits	Scale Factor (LSB)	Effective Range	Units
IODP	2	1	0-3	unitless
PRN Mask No.	6	1	0-51	unitless

Parameter	No. of Bits	Scale Factor (LSB)	Effective Range	Units
Scale Exponent	3	1	0-7	unitless
E <sub>1,1</sub>	9	1	0-511	unitless
E <sub>2,2</sub>	9	1	0-511	unitless
E <sub>3,3</sub>	9	1	0-511	unitless
E <sub>4,4</sub>	9	1	0-511	unitless
E <sub>1,2</sub>	10	1	±512	unitless
E <sub>1,3</sub>	10	1	±512	unitless
E <sub>1,4</sub>	10	1	±512	unitless
E <sub>2,3</sub>	10	1	±512	unitless
E <sub>2,4</sub>	10	1	±512	unitless
E <sub>3,4</sub>	10	1	±512	unitless
PRN Mask No.	6	1	0-51	unitless
Scale Exponent	3	1	0-7	unitless
E <sub>1,1</sub>	9	1	0-511	unitless
E <sub>2,2</sub>	9	1	0-511	unitless
E <sub>3,3</sub>	9	1	0-511	unitless
E <sub>4,4</sub>	9	1	0-511	unitless
E <sub>1,2</sub>	10	1	±512	unitless
E <sub>1,3</sub>	10	1	±512	unitless
E <sub>1,4</sub>	10	1	±512	unitless
E <sub>2,3</sub>	10	1	±512	unitless
E <sub>2,4</sub>	10	1	±512	unitless
E <sub>3,4</sub>	10	1	±512	unitless

The elements of  $R$  can be written as:

$$R = SF \cdot E \quad (5-34)$$

where,  $SF = 2^{(scale\ exponent-5)}$ ,  $E = \begin{bmatrix} E_{1,1} & E_{1,2} & E_{1,3} & E_{1,4} \\ 0 & E_{2,2} & E_{2,3} & E_{2,4} \\ 0 & 0 & E_{3,3} & E_{3,4} \\ 0 & 0 & 0 & E_{4,4} \end{bmatrix}$ .

The relative covariance matrix  $C$  can be gotten by  $R$  as:

$$C = R^T \cdot R \quad (5-35)$$

The UDRE degradation parameter  $\delta UDRE$  is specified as:

$$\delta UDRE = \sqrt{I^T \cdot C \cdot I} + \varepsilon_c \quad (5-36)$$

where,  $I$  is the 4-D line of sight vector from the user to the satellite (the first three

components are the unit vector from the user to the satellite and the fourth component is a one);  $\varepsilon_c = C_{covariance} \cdot SF$ ,  $C_{covariance}$  is broadcast by Message Type 10, if  $C_{covariance}$  in Message Type 10 is not available,  $\varepsilon_c$  is set to 0.

### 5.3.15 Message Type 62

Message Type 62 is used for internal testing purposes.

### 5.3.16 Message Type 63

Message Type 63 is a null message, it is used as a filler message if no other message is available for broadcast for the one-second time slot.

## 5.4 Degradation Parameters

### 5.4.1 Fast and Long-Term Correction Degradation

The residual error associated with the fast and long-term corrections is characterized by the variance ( $\sigma_{flt}^2$ ) of a model distribution. This term is computed as:

$$\sigma_{flt}^2 = \begin{cases} \left( \sigma_{UDRE} \cdot \delta UDRE + \varepsilon_{fc} + \varepsilon_{rrc} + \varepsilon_{ltc} + \varepsilon_{er} \right)^2, & RSS_{UDRE} = 0 \\ \left( \sigma_{UDRE} \cdot \delta UDRE \right)^2 + \varepsilon_{fc}^2 + \varepsilon_{rrc}^2 + \varepsilon_{ltc}^2 + \varepsilon_{er}^2, & RSS_{UDRE} = 1 \end{cases} \quad (5-37)$$

where,  $RSS_{UDRE}$  is the root-sum-square flag in Message Type 10;  $\sigma_{UDRE}$  is the model parameter from Message Types 2-6, 24;  $\delta UDRE$  is defined in Message Type 28;  $\varepsilon_{fc}$  is the degradation parameter for fast correction data;  $\varepsilon_{rrc}$  is the degradation parameter for range rate correction data;  $\varepsilon_{ltc}$  is the degradation parameter for long term correction;  $\varepsilon_{er}$  is the degradation parameter for en route through NPA applications.

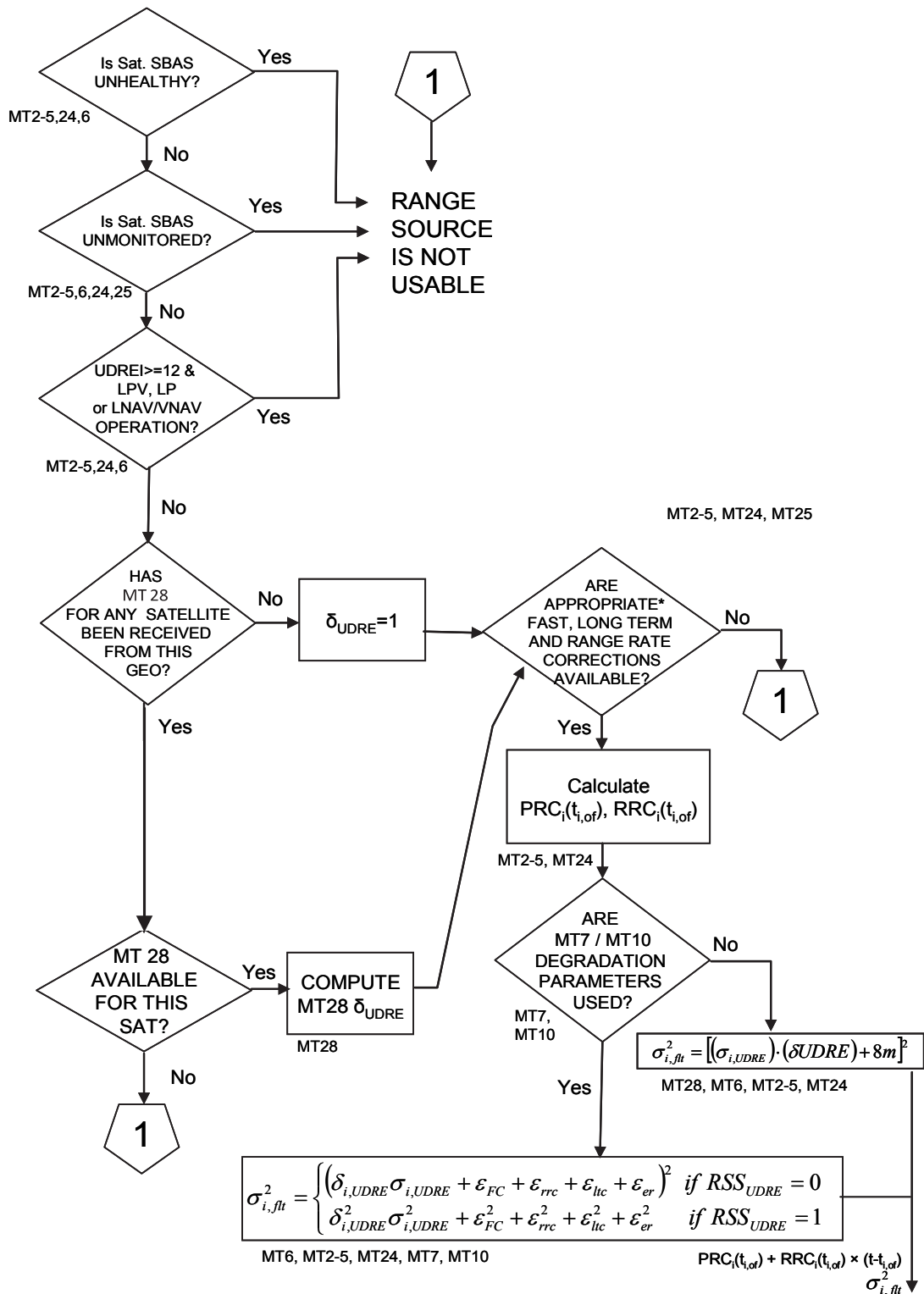

Figure 5-24 Processing Flow of Fast and Long-Term Correction Degradation

### 5.4.1.1 Fast Correction Degradation

The degradation parameter for fast correction data is defined as:



$$\varepsilon_{fc} = a(t - t_u + t_{lat})^2 / 2 \quad (5-38)$$

where,  $a$  is the fast correction degradation factor determined from Message Type 7.  $t$  is the current time.  $t_u$  is the application time of fast correction; For UDREIs broadcast in Types 2-5 and 24,  $t_u$  equals the time of applicability of the fast corrections; For UDREIs broadcast in Type 6 and if the IODF=3,  $t_u$  also equals the time of applicability of the fast corrections; For UDREIs broadcast in Type 6 and IODF  $\neq$  3,  $t_u$  is defined to be the time of transmission of the first bit of Message Type 6 at the GEO.  $t_{lat}$  is the system latency determined from Message Type 7.

#### 5.4.1.2 Range-Rate Correction Degradation

If  $ai_i = 0$ , then the range-rate correction degradation ( $\varepsilon_{rrc}$ ) is equal to 0. Otherwise,  $\varepsilon_{rrc}$  is divided into two cases.

(1) The IODFs of both the current and previous fast corrections are not equal to 3

$$\varepsilon_{rrc} = \begin{cases} 0 & , |IODF_{current} - IODF_{previous}|_3 = 1 \\ \left( \frac{aI_{fc,j}}{4} + \frac{B_{rrc}}{\Delta t} \right) (t - t_{of}) & , |IODF_{current} - IODF_{previous}|_3 \neq 1 \end{cases} \quad (5-39)$$

(2) At least one of the IODFs is equal to 3

$$\varepsilon_{rrc} = \begin{cases} 0 & , |\Delta t - I_{fc,j} / 2|_2 = 0 \\ \left( \frac{a|\Delta t - I_{fc,j} / 2|}{2} + \frac{B_{rrc}}{\Delta t} \right) (t - t_{of}) & , |\Delta t - I_{fc,j} / 2|_2 \neq 0 \end{cases} \quad (5-40)$$

where,  $a$  ( $ai_i$ ) is the fast corrections degradation factor determined from Message Type 7;  $t$  is the current time;  $I_{fc,j}$  is the shortest time-out interval for any satellite included in the associated fast corrections in Message Type 2-5 or 24;  $B_{rrc}$  is derived from Message Type 10;  $IODF_{current}$  is the IODF associated with most recent fast correction;  $IODF_{previous}$  is the IODF associated with previous fast correction;  $t_{of}$  is the time of applicability of the most recent fast correction;  $t_{of,previous}$  is the time of applicability of the previous fast correction;  $\Delta t = t_{of} - t_{of,previous}$ .

#### 5.4.1.3 Long Term Correction Degradation

The degradation associated with long-term corrections is covered by two cases depending on whether both offset and velocity (Type 24 or 25 with velocity code=1) or only offset (Type 24 or 25 with velocity code=0) is included in the message.

(1) velocity code=1

$$\varepsilon_{lrc} = \begin{cases} 0 & , t_0 < t < t_0 + I_{lrc\_vl} \\ C_{lrc\_lsb} + C_{lrc\_vl} \max(0, t_0 - t, t - t_0 - I_{lrc\_vl}) & , otherwise \end{cases} \quad (5-41)$$

where,  $t$  is the current time;  $t_0$  is the time of applicability for the long term correction;  $I_{lrc\_vl}$  is the update interval determined from Message Type 10;  $C_{lrc\_lsb}$  is the maximum round-off error determined from Message Type 10;  $C_{lrc\_vl}$  is the velocity error determined from Message Type 10.

(2) velocity code=0

$$\varepsilon_{lrc} = C_{lrc\_v0} \left\lfloor \frac{t - t_{lrc}}{I_{lrc\_v0}} \right\rfloor \quad (5-42)$$

where,  $t$  is the current time;  $t_{lrc}$  is the time of transmission of the first bit of the long term correction message at the GEO;  $I_{lrc\_v0}$  is the minimum update interval determined from Message Type 10;  $C_{lrc\_v0}$  is determined from Message Type 10;  $\lfloor x \rfloor$  means the floor or greatest integer less than  $x$  function.

(3) GEO Navigation Message Degradation

$$\varepsilon_{lrc} = \begin{cases} 0 & , t_0 < t < t_0 + I_{geo} \\ C_{geo\_lsb} + C_{geo\_v} \max(0, t_0 - t, t - t_0 - I_{geo}) & , otherwise \end{cases} \quad (5-43)$$

where,  $t$  is the current time;  $t_0$  is the time of applicability for the GEO navigation message;  $I_{geo}$  is the update interval for GEO navigation messages determined from Message Type 10;  $C_{geo\_lsb}$  is the maximum round-off error determined from Message Type 10;  $C_{geo\_v}$  is the velocity error determined from Message Type 10.

#### 5.4.1.4 Degradation for En Route Through LNAV

When using fast or long term corrections which have timed out for LNAV/VNAV, LP, or LPV approach, but have not timed out for other navigation modes, an extra “catch-all” degradation factor is applied. This degradation is:

$$\varepsilon_{er} = \begin{cases} 0, & \text{neither fast nor long term corrections} \\ & \text{have timed out for approach (LNAV / VNAV,LP,LPV)} \\ C_{er}, & \text{if fast or long term corrections} \\ & \text{have timed out for approach (LNAV / VNAV,LP,LPV)} \end{cases} \quad (5-44)$$

where,  $C_{er}$  is determined from Message Type 10.

### 5.4.2 Degradation of Ionospheric Corrections

The residual error associated with the ionospheric corrections is characterized by the

variance ( $\sigma_{ionogrid}^2$ ). This term is computed as:

$$\sigma_{ionogrid}^2 = \begin{cases} (\sigma_{GIVE} + \varepsilon_{iono})^2 & , RSS_{iono} = 0 \\ \sigma_{GIVE}^2 + \varepsilon_{iono}^2 & , RSS_{iono} \neq 0 \end{cases} \quad (5-45)$$

$$\varepsilon_{iono} = C_{iono\_step} \left\lfloor \frac{t - t_{iono}}{I_{iono}} \right\rfloor + C_{iono\_ramp} (t - t_{iono}) \quad (5-46)$$

where,  $RSS_{iono}$  is determined from Message Type 10;  $\sigma_{GIVE}$  is determined from Message Type 26;  $t$  is the current time;  $t_{iono}$  is the time of transmission of the first bit of the ionospheric correction message at the GEO;  $C_{iono\_step}$  is determined from Message Type 10;  $C_{iono\_ramp}$  is determined from Message Type 10;  $I_{iono}$  is the minimum update interval for ionospheric correction messages determined from Message Type 10;  $\lfloor x \rfloor$  means the floor or greatest integer less than  $x$  function.

## 6 Abbreviations

A-SBAS	African SBAS
BDS	BeiDou Navigation Satellite System
BDSBAS	BeiDou Satellite Based Augmentation System
BDT	BeiDou Navigation Satellite System Time
BIPM	International Bureau of Weights and Measures
BPSK	Binary Phase Shift Keying
CRC	Cyclic Redundancy Check
DFMC	Dual-Frequency Multi-Constellation
ECEF	Earth Centered Earth Fixed
EGNOS	European Geostationary Navigation Overlay System
FEC	Forward Error Correction
GAGAN	GPS Aided GEO Augmented Navigation system
GEO	Geostationary Earth Orbit
GIVE	Grid Ionospheric Vertical Error
GIVEI	Grid Ionospheric Vertical Error Indicator
GLONASS	Global Navigation Satellite System
GPS	Global Positioning System
GPST	GPS Time
ICAO	International Civil Aviation Organization
ICD	Interface Control Document
IGP	Ionospheric Grid Point
IOD	Issue of Data
IODF	Issue of Data Fast correction
IODP	Issue of Data, PRN mask
KASS	Korean Augmentation Satellite System
LSB	Least Significant Bit
LNAV	Lateral NAVigation
LP	Localizer Performance
LPV	Localizer Performance with Vertical guidance

MSAS	MTSAT Satellite-based Augmentation System
MSB	Most Significant Bit
NICT	National Institute of Information and Communications Technology
NIST	National Institute of Standards and Technology
NTSC	National Time Service Center Chinese Academy Of Sciences
PRN	Pseudo Random Noise
SARPs	Standards And Recommended Practices
SBAS	Satellite Based Augmentation System
SDCM	System of Differential Correction and Monitoring
SF	Single Frequency
SIS	Signal-In-Space
SNT	SBAS Network Time
SPAN	Southern Positioning Augmentation Network
TOW	Time Of Week
UDRE	User Differential Range Error
UDREI	User Differential Range Error Indicator
URA	User Range Accuracy
USNO	U. S. Naval Observatory
UTC	Universal Time Coordinated
VNAV	Vertical NAVigation
WAAS	Wide Area Augmentation System
WGS-84	World Geodetic System 84
WN	Week Number